

MIXING HEAD

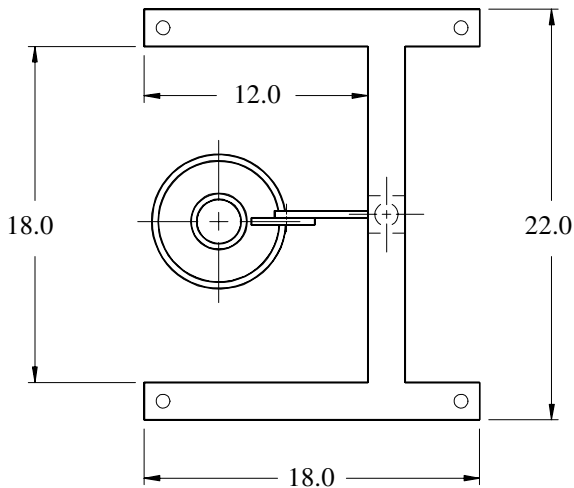

ITEM	QTY	DESCRIPTION	MATL
1	1	Bearing frame	316 SS
2	1	Motor: as per proposal	
3	1	Shaft	316 SS
4	1	Adjustable Floor Stand	304 SS
5	1	ROTOSOLVER mixing head	316 SS



Advanced Mixing Technologies

ROTOSOLVER

RSO2 with stainless steel adjustable floor stand